

# A Survey on Various Wireless Sensor Network and Embedded Techniques for Security in Railways

**Vigneshwari Rajagopal**

Pervasive Computing Technology, Bharathidasan Institute of Technology, Anna University Regional Centre,  
Tiruchirappalli, Tamil Nadu 620024, India

## Abstract

Railways are considered as the safest mode of transportation. But, thousands of people die due to train accidents. Derail and collision occur every ninety minutes. More than 10,000 such accidents had occurred over last eight years. Human error, signal misperception, system failure, improper maintenance of tracks and points are considered to be the main reasons. Many of such major accidents happen that could have been completely preventable by controlling the train parameters. In this paper, a survey on various technologies such as Wireless Sensor network and Embedded system which could be efficiently used to prevent such accidents along with their advantages and challenges are presented so that enhanced security could be achieved in rail transportation.

**Keywords:** *Wireless Sensor Network, Embedded System, Railways, Accidents, Safety, MAC Protocols*

## 1. Introduction

Rail transportation requires more safety. The motivation of choosing this problem domain is discussed in 1.1 and 1.2. Also the survey of various enabling technologies for train parameter monitoring and for achieving safety in railways is presented in section 3. Basic approach of using Wireless Sensor Network in railways is discussed in 3.1. Various Routing and MAC Protocols suitable for this safety application is given in sections 3.2 and 3.3 respectively. In section 3.4 the justification for the need of new WSN Communication Protocol suitable for this application is given. Various real time Embedded Techniques for achieving safety in railways is discussed in 3.5

### 1.1 Issues with safety

Government of India ministry of Railways in [1] mentioned about the statistics of Train accidents. The following table lists the details of Train Accidents on Indian Railways:

Table 1: Survey of Train accidents in Indian Railways

Year	Collisions	Derailment	Accidents	Fire	Total
2004-05	13	138	70	10	234
2005-06	9	131	75	15	234
2006-07	8	96	79	4	195
2007-08	8	100	77	5	194
2008-09	13	85	69	3	177
Details from [16]					
2012	6	38	41	7	90
2013	3	43	35	5	88

In [1] it is also mentioned that in order to **achieve safety, new technologies** have to be incorporated with railways. Indian Railways lack in existing infrastructure. With the same available number of tracks for many years, they are increasing the number of trains and speed which leads to accidents.

Nisha S.Punekar et al, in [2] pointed out that rail transportation **requires more safety** since the number of trains running along the same existing tracks gets increasing. The number of collisions occurring world-wide shows increasing tendency year by year. The Author also mentioned that only very **few number of publications** only can be found that are dealing with investigations into the

train collision process. This is due to the complicated character of the dynamics of train crashes.

### 1.2 Need for Alternative Techniques

Somnath Banerjee in [3] explained the basic logic they use in railways.

- It is understood that the tracks are divided into blocks and only one train is allowed to occupy one block at a time, in order to avoid accidents. In case if a driver misses a signal, then *only partial safety* could be provided by the railways. So this clearly indicates that the safety is not ensured completely.
- Also it is understood that still railways are employing *old fashioned* mechanical interlocking techniques and had not adapted to any of the new technologies, because in order to adapt, it has to be completely fail safe technique. So this indicates that there is need for such techniques.

## 3. Literature Review

### 3.1 Wireless Sensor Network [WSN] for Railways

Sandeep Patalay in [4] gave a basic approach of how the sensor network could be utilized in railways. Use of sensor nodes with a special node called driving node at the locomotive engine, Gateway node and a Base station could achieve an architecture needed for this scenario. The idea that is understood from this paper is shown in figure 1.

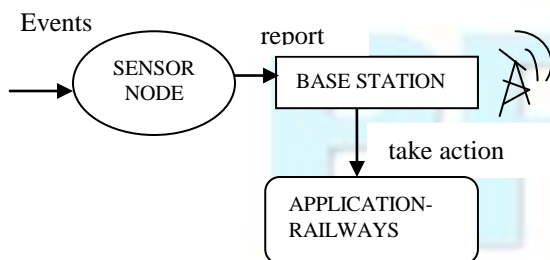

Fig. 1 Basic Approach of using Sensor node in railways

The sensor nodes could detect the events occurring and could be triggered. The sensor node reports the events to the base station which could further take actions that depends on the applications. For e.g. In closing of railway gates automatically once arrival of train is detected. In this scenario the event is the arrival of train and a vibration sensor which was laid in the track could detect this event and could report it to the nearby base station which then

sends commands to do the action which is here the closure of gates.

This basic approach can be applied in two ways:

#### On Signalling:

- To detect the presence of trains
- To detect the strength of the signal
- To detect the presence of vehicles at crossing gates

#### On Engines:

- To monitor different parameters such as:
- Brake pressure
- Speed of the engine

The sensor nodes are fitted to the carriages at a distance of four hundred meters apart which communicates to the driver node at the Engine which then transmits the information to the Gateway node. A wired backend could serve as the communication medium for the communication between the gateway node and the Base station. The base station can then send back the commands to the driver node.

Zeinab Sam Daliri, et.al., in [5] have given the method for providing security in railways through wireless sensor networks based on Fuzzy Logic which acquired the basic sensor network architecture and multi-layer routing from that of paper [7] and includes ultrasonic broken flaw detecting system. This system includes a transmitter which sends out high energy waves in two directions at estimated intervals. The break in rails will be indicated by the change in the amplitude of the waves. It has a system for tracking any materials in tracks which employs either image processing by analyzing the images captured by the cameras or leaky cable method for areas where there are possibility of landslides.

**Fuzzy logic:** This logic is used in this work, to take decision for the problems in railways. The input variables regarding the defects and their acceptable ranges of defects are defined and the sensors recognize the cracks and other parameters. Fuzzy rules are set whether to on the Alarm or not under the combination of the input variables. And the output variables that are divided into subcategories for example: Low, Medium, High ranges.

A. Pascale, et.al., in [6] suggested the use of the wireless signaling for the computer based interlocking system in railways. In this architecture, they used a basic term Field devices that mentions about devices, sensor nodes which are fitted along the rail tracks and are located in the field network areas that consists of many individual field networks. Separate controllers for each network communicate using IEEE 802.15.4 to the Access point which further utilizes Wimax or GPRS connection to

communicate with the control room. The authors concentrated on optimizing the number of deployed Access Points by reducing it with maximum reliability and minimal delay using Greedy approach and ILP formulation.

### 3.2 Routing Protocols suitable for this Scenario

Various Routing protocols suitable for this WSN scenario in railways as mentioned in [4] are:

**Flat Routing:** It works like multihop adhoc routing protocol with each sensor node forwards the data through a parent node, but not as hierarchical clusters.

**Assumption:** All the location details of the sensor nodes, base station are known.

**Advantage:** All nodes can reach the base station wherever they are located.

**Tiny OS Beaconing:** Beacon messages are broadcast to the network by the base station. The nodes closer to the base station receives this message and assume it as its Parent node and further broadcast the message to its nearest nodes and so on. Later sensory data is periodically sent by the sensor nodes to its parent nodes which is further forwarded to their parents to reach the base station.

**Advantages:**

No need of huge routing tables.

Can save power by remaining off most of the time.

**Drawbacks:**

Affected by node failures: If parent node fails, entire sub tree gets affected.

Power Consumption varies across the nodes: Closer the nodes to the base station power consumption are more.

**Pulse routing algorithm:** This algorithm has a Pulse source which uses a Periodic Pulse signal and this pulse is flooded to construct routing paths. Communication needs a reservation packet to be sent by the source.

**Advantages:**

Faster activation of paths, lesser energy consumption

Has path deactivation facility also.

Emad Aboelela, et.al, in [7] proposed a network for the railways scenario includes sensor nodes with data processing sink node and a control center. And routing is based on multilayered to achieve reduced power loss compared to that of direct transmission. **Multilayer Routing** described occurs as shown as in figure2.

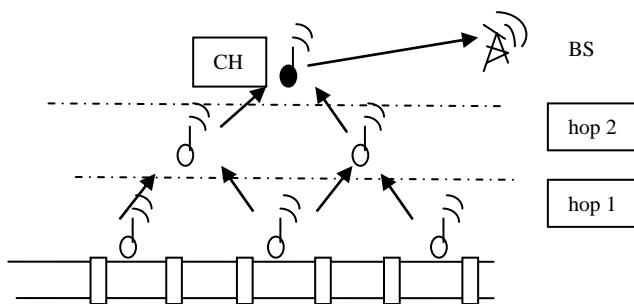

Fig.2 Inferred Routing for WSN along railtrack

Sensor nodes are placed in and around the tracks forming different layers as shown. Sensor nodes which are fitted to the tracks at regular intervals form the layer two, and at fixed distance away from this layer two, forms another layer called Layer one to which each node in Layer two communicates and send sensed information. Layer one in their next hop sends this obtained information to their corresponding Cluster head which aggregates the sensor values from two of its layer one nodes and sends this to the base station which further takes appropriate action or send it to sink nodes.

**Inference:**

(1) From this paper, the sensor nodes setup for our specific application and a basic routing methodology is well understood and could use the same with little modifications during the implementation of setting up of the nodes.

(2) Multihop routing is more suitable than single hop because the energy spent on data transmission is lesser than that of single hop routing.

### 3.3. Wireless MAC Protocols for Railways Scenario

Jing Li et.al in [8] have proposed a protocol based on communication among clusters called BMA (Bit Map assisted Protocol). This Protocol reduces energy wastage due to collision and idle listening. It is based on the Event-driven networks, where sensor nodes forward data to the Cluster head, only if a significant event is detected. In BMA, the allocation is done in the contention phase before the starting of each frame and so BMA is more energy efficient than TDMA and E-TDMA for low traffic. It has two phases:

**Cluster Setup phase:** Cluster head is elected based on the energy levels of the nodes and other non cluster nodes join the cluster group that requires lower energy for communication.

**Steady-State Phase:** Assumption is made that the data slots have same size. This phase have many sections each consists of contention period, data propagation period and idle period. Contention period is utilized by the nodes whichever have the data to transmit and indicates it by transmitting one-bit control message in its allocated slot or else remains silent. So, then the cluster head got the details of which nodes wish to transmit and so transmission schedule is sent for the source nodes by broadcasting. In the data Propagation period, the source nodes sends its data and then go to off state other than is scheduled time.

G. M. Shafiullah et.al in [9] explained about various energy efficient MAC Protocols specific for Railway Monitoring Applications with their limitations and proposed a new protocol called E-BMA. They are:

**TDMA:** Schedule based MAC protocol, node has to be on even if it has no data to send during its allocated slot. So energy consumption is high.

**E-TDMA:** uses idle listening to reduce energy consumption. Other than the Cluster head all other nodes remain in off condition when there is no data to transmit. But the cluster head has to be always ON all time which leads to wastage of energy.

**BMA:** Bit Map Assisted Protocol reduces energy wastage due to collision and idle listening. It is based on the Event-driven networks, where sensor nodes forward data to the Cluster head, only if a significant event is detected. In BMA, the allocation is done in the contention phase before the starting of each frame and so BMA is more energy efficient than TDMA and E-TDMA for low traffic.

**E-BMA:** Energy efficient Bit Map Assisted Protocol which uses piggy packing technique than sending an entire control message, to make reservations of the corresponding slot. It uses one bit field in header to indicate if any successive data packets are available which then helps the source node to wait for one more frame to check for the availability of the concurrent data packets. So this E-BMA protocol differs from the BMA which make the reservation in the contention slot as soon as the data packet is available. It has three phases for each round.

Setup Phase: Cluster head formation, Cluster head selection.

Contention Phase: reservation of data slots by the non-cluster head nodes.

Data transmission Phase: nodes send their data to the Cluster Head. Data Aggregation takes place in Cluster Head and then send it to the Base station using a spreading methodology and a Carrier sense multiple access technique.

#### Conclusion:

- The E-BMA protocol is better in terms of the energy efficiency for the low to medium traffic under simulation modeling of a Wireless Sensor Network scenario. Further energy efficiency could be achieved in this protocol by further modifications suitable for our application scenario.
- Also it is understood from this paper that, instead of Bluetooth, IEEE 802.15.4 Zigbee standard a very low power and low data rate standard is suitable for railway applications. So this module could be used with existing infrastructures.

### 3.4 Justification for the need of New Protocol

Scholten, J. et.al in [10] have proposed a protocol to perform train integrity check. Here overview of communication among the sensor nodes deployed in the carriages has been given. From this paper it is noticed that the wireless sensor network with the nodes in each compartment form a *linear structure*, and so existing communication protocols do not apply well here. So, the communication occurs like:

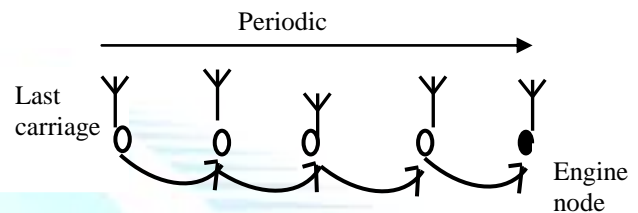

Fig. 3 Node Communication for train integrity check

So the Communication differs from general protocols in the following manner:

- The nodes only need to reach their immediate neighbor nodes and the locomotive node. So the routing algorithms can be placed very simple.
- There will not be communication via different paths, since the nodes are aligned more or less in straight lines as shown in figure 1.
- Only the Engine node needs to know the topology.
- Synchronization can also be combined with other communications.
- Collision avoidance can be much easier, since sending and receiving is regulated.

**Inference:** So a Protocol suitable for the sensor nodes communication in the train carriages differs from the general protocols and so a new energy efficient protocol suitable for this scenario can be developed.

### 3.5 Embedded Techniques To Control Train Parameters:

Satheesh kumar in [11] suggested the use of Multicore Embedded Processor for enhanced performance in control and communication systems. Here, Sensor nodes are connected with wireless link to detect fire in coaches. Multi core Processor is an Integrated Circuit with more than two Processors which:

- improves performance.
- reduces power consumption.
- efficiency in processing.

Other units could well be attached to the MCEP which acts as the central coordinator for this architecture.

Compartment module, flaw inspection by ultrasonic approach, Track dimensions monitoring module and so on are connected to this MCEP, which works as:

Sensor nodes will communicate through the wireless link to the locomotive engine. So, Train will be stopped automatically, in case if any fire happens at any carriage. Track monitoring systems are installed in critical places where mishaps are anticipated like landslide prone zones and places where tunneling is happening along with other sensors to monitor the track in real time. It sent alerts to the MCEP in case of any abnormalities.

**Drawback:** In this paper the author suggested the use of Non-Contact laser-based Ultrasonic rail flaw detection for the cracks, breaks detection of rails. But this method is considered as a slow process which requires lot of time.

**Inference:** It is understood that embedded system forms the important part to provide real time results achieving better accuracy and faster response. Also the author mentioned that his future work as functional improvements using advanced sensor systems. So in future models sensor nodes with ZigBee could be used to form a network and a protocol could be designed for this specific scenario which could be more energy efficient than existing protocols.

G.Anjali bissha, et.al., in [12] suggested a system for Train Collision Avoidance Using Vibration Sensors And Zigbee Technology in which they used :

**Vibration sensor:** that uses piezoelectric effect to detect the vibrations along the track, whenever train arrives and departs and feeds this information to the microcontroller which then informs to the control room.

**Proximity LASER Detector:** This is used to avoid the running train getting collided with a standing train that uses Laser diode which is fitted to the locomotive that generates laser signals to detect the presence of any other trains before the train to which it is connected. The detection is known by the reception of the collided laser signal with that of opposite signal from other trains.

S.Ramesh et.al, in [13] have suggested a technique for detecting cracks and avoiding collisions in the tracks using wireless sensor network. It involves:

**Crack detection:** IR sensors could be used which utilizes IR rays to detect cracks. IR receiver is connected to the Controller and electric lamps which is further connected to the coordinator node and the information via GSM to the nearest station.

**Collision Avoidance:** Sensors are fitted to the train wheels and IR rays are transmitted in the track. The same facility, if made available in the opposite trains also, then Alarm is made on and get alerts if they are in same track, because

the two rays would get collided and get back to their corresponding engines.

#### 4. Conclusions

This paper presents a survey on various technologies for providing security in railways such as Embedded System, Wireless Sensor network and its routing and MAC protocols suitable for this application. So existing WSN Protocols and embedded techniques have various drawbacks. Several techniques from each paper could be integrated to be used along with the existing railways infrastructure since entire replacement of existing techniques in railways is not possible.

So based on the inferences understood from each paper, new architecture could be formed. For e.g A basic idea of how to apply the sensor network to the railways scenario is well understood from [4]. A basic sketch that is taken from this paper to proceed further with the project design is as shown below:

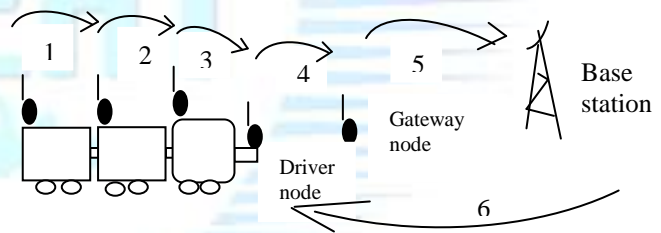

Figure 4 Inferred basic Idea for forming a sensor network in trains

#### References

- [1] Government of India ministry of Railways (Railway Board), "India Railways Vision 2020", 2009.
- [2] Nisha S.Punekar and Archana Raut, "A Survey on Railway Security in Wireless Network" International Journal of Computer Science and Network,(IJCSN ) Vol 2, Issue 1, 2013 ISSN (Online) : 2277-5420
- [3] Somnath Banerjee, "Basics of Railway Signaling" Edition 5.0, 2012.
- [4] Sandeep patalay, "Railway Signaling Using Wireless Sensor Network", white paper, 2010.
- [5] Zeinab Sam Daliri, Shahaboddin Shamshirband, Mohsen Amiri Besheli, "Railway security through the use of wireless sensor networks based on Fuzzy Logic", International Journal Of Physical Sciences, Vol.6(3), 2011, pp. 448-458.

- [6] A Pascale, N.Varanese, G.Maier, U.Spagnolini “A Wireless sensor network architecture for railway signaling”, in Italian Networking workshop, 2012.
- [7] Emad Aboelela, William Edberg, Christos Papakonstantinou and Vinod Vokkarane “Wireless Sensor Network Based Model for Secure Railway Operations” 2006 IEEE In.Perf.Com.Comm.Conf.,83.
- [8] Jing Li and Georgis Y.Lazarou “A Bit Map-Assisted Energy-Efficient MAC Scheme for wireless Sensor Networks”, IPSN 2004, ACM.
- [9] G. M. Shafiullah, Salahuddin A. Azad, and A. B. M. Shawkat Ali “Energy-Efficient Wireless Mac Protocols for Railway Monitoring Applications”, IEEE transactions on intelligent transportation systems, 2013, vol. 14, no. 2, pp.649-659.
- [10] Scholten, J. , Westenberg, R. and Schoemaker, M. “Trainspotting, a WSN-Based Train Integrity System”, in The Eighth International Conference on Networks, ICN 2009, pp. 226-231.
- [11] Sathesh kumar, “An Efficient Way Of Monitoring & Controlling Train Parameters Using MCEP”, 3rd IEEE conference ICCSIT 2010, Vol 9, pp. 552-555.
- [12] G.Anjali bissa, S.Jayasudha, R.Narmatha and B.Rajmohan “Train Collision Avoidance System Using Vibration Sensors And Zigbee Technology” IJREAT, Vol. 1, No.1.
- [13] S.Ramesh, A.Gobinathan “Railway Fault Tolerance Techniques using Wireless Sensor Networks”, IJECT Vol 3, Issue 1, March 2012.
- [14] Beakcheol Jang , “Wireless MAC Protocol Design and Analysis” Doctoral Dissertation, North Carolina State University, ACM DL, 2009.
- [15] Webpage-“Major Causes of Train Accidents SettlementBoard.com”
- [16] V.K. Rakesh Reddy, “Track Record of Accidents, Incidents in 2012 and 2013”, THE HINDU, December 28,2013.